

NUMAX

NUMAX

MODEL: **S18GLCNDH**

- [HTTP://WWW.NUMAXTOOLS.COM](http://www.numaxtools.com)
- 1-888-669-5672
- PRIME GLOBAL PRODUCTS, INC.

18 GAUGE L CLEAT FLOORING NAILER

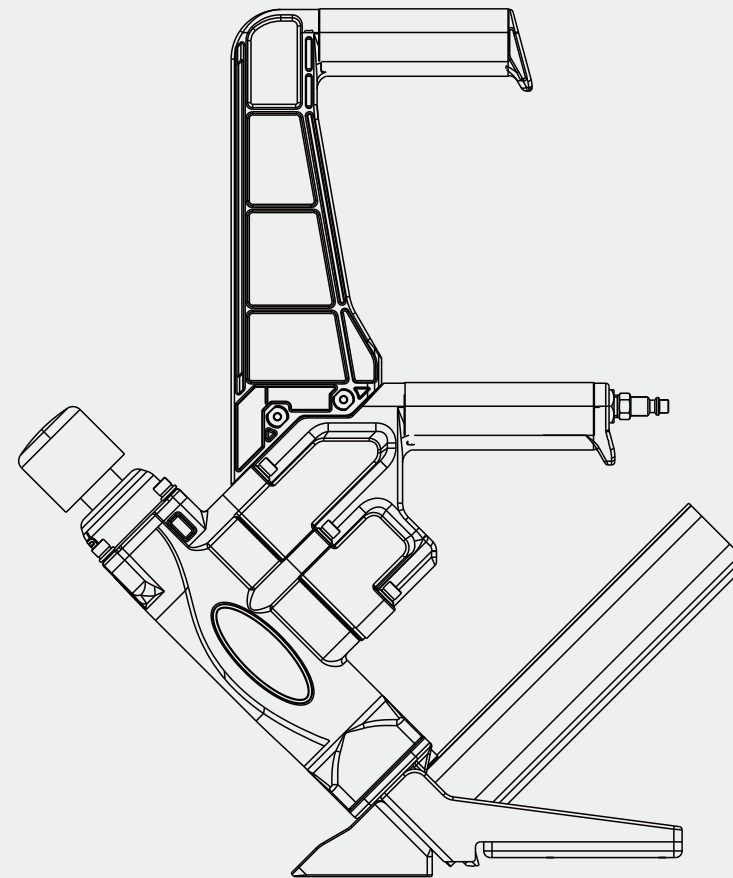

WARNING:

Failure to follow warnings could result in **DEATH OR SERIOUS INJURY.**

SAVE THIS MANUAL FOR FUTURE REFERENCE.

- [HTTP://WWW.NUMAXTOOLS.COM](http://www.numaxtools.com)
- 1-888-669-5672
- PRIME GLOBAL PRODUCTS, INC.

GENERAL SAFETY RULES	P3
UNPACKING	P5
FEATURES	P6
OPERATION	
PREPARE THE TOOL	P6
LOADING L CLEATS	P7
UNLOADING L CLEATS	P8
CHANGING THE FOOT PLATE	P8
ADJUSTING THE FRONT FOOT	P9
SETTING THE AIR PRESSURE	P9
OPERATING THE TOOL	P9
CLEARING JAMS	P10
MAINTENANCE	P11
RECOMMENDED HOOKUP	P12
TROUBLESHOOTING	P14
WEARABLE PARTS	P15
WARRANTIES	P15

⚠ WARNING:

The warnings and precautions discussed in this manual cannot cover all possible conditions and situations that may occur. Please be aware of the potential hazards, and take all necessary precautions to avoid risk of injuries.

SAVE THIS MANUAL

- Keep this manual for the safety warnings, precautions, operations, inspections and maintenance information. Keep this manual and the receipt in a safe and dry place for future reference.

⚠ WARNING:

To avoid serious personal injury, do not attempt to use this product until you read the manual thoroughly and understand it completely. Save this manual and review frequently for continuing safe operation and instructing others who may use this tool.

SYMBOLS

- The following signal words and meanings are intended to explain the levels of risk associated with this tool, and can be found in the manual, packaging, labeling, and all other information provided with this tool:

SYMBOLS	SIGNAL	MEANING
	WARNING:	Indicates a potentially hazardous situation, which, if not avoided, could result in death or serious injury.
	CAUTION:	Indicates a potentially hazardous situation, which, if not avoided, may result in minor or moderate injury.
	CAUTION:	(Without symbol) Indicates a situation that may result in property damage.

GENERAL SAFETY RULES

INSTRUCTIONS PERTAINING TO A RISK OF FIRE, ELECTRIC SHOCK, OR INJURY TO PERSONS.

⚠ WARNING:

When using tools, basic precautions should always be followed, including the following:

CALIFORNIA PROPOSITION 65

⚠ WARNING:

This product can expose you to chemicals including lead, which is known to the State of California to cause cancer and birth defects or other reproductive harm. For more information, go to www.P65Warnings.ca.gov.

WORK AREA

- Keep the work area clean and well lit. Cluttered benches and dark areas increase the risks of accidents.
- Do not operate the tool in explosive atmospheres, such as in the presence of flammable liquids, gases, or dust. The tool creates a spark which may ignite flammable liquids, gases or dust.
- Keep bystanders, children, and others away while operating the tool. Distractions could result in improper use and cause injury.
- Avoid unintentional misfires. Always use caution to avoid accidentally firing. Do not point at yourself or anyone else regardless if it contains fasteners or not.

PERSONAL SAFETY

Always wear eye protection. Operator and others in the work area should always wear ANSI-approved safety goggles with side shields. Eye protection is used to guard against flying fasteners and debris, which may cause severe eye injury.

Always wear hearing protection when using the tool. Prolonged exposure to high intensity noise may cause hearing loss.

Use safety equipment. A dust mask, non-skid safety shoes and a hard hat must be used for the applicable conditions. Wear a full face shield if you are producing metal filings or wood chips.

Dress properly. Do not wear loose clothing or jewelry. Contain long hair. Keep your long hair, clothing, and gloves away from moving parts. Loose clothes, jewelry, or long hair can be caught in moving parts.

Stay alert, watch what you are doing and use common sense when operating a power tool. Do not use tool while tired or under the influence of drugs, alcohol, or medication. A moment of inattention while operating the tool may cause serious injury. Avoid unintentional firing. Keep fingers away from hammer when not driving fasteners, especially when connecting the tool to the air supply.

Keep proper footing and balance at all times. Proper footing and balance enables better control of the tool in unexpected situations.

Do not use on a ladder or unstable supports. Stable footing on a solid surface enables better control of the tool in unexpected situations.

- Make sure the hose is free of obstructions or snags. Entangled or snarled hoses can cause loss of balance or footing and may become damaged, resulting in possible injury.
- Wash hands after handling. This product or its power cord may contain chemicals known to the State of California to cause cancer and birth defects or other reproductive harm.

TOOL USE AND CARE

- Know this tool. Read manual carefully, learn its applications and limitations, as well as the specific potential hazards related to this tool.
- Only use fasteners that are recommended for your models. Do not use the wrong fasteners or load the fasteners incorrectly.
- Check for misalignment or binding of moving parts, breakage of parts, and any other condition that may affect the tool's operation. If damaged, have the tool serviced before using. Many accidents are caused by poorly maintained tools.
- Maintain tools with care. Keep tool clean. A properly maintained tool reduces the risk of binding and is easier to control.
- Store tools out of the reach of children and other untrained people. Tools are dangerous in the hands of untrained users.
- Check operation of the tool before use. Do not use the tool if the workpiece contact mechanism is not working correctly as accidental driving of a fastener may occur.
- Do not force tool. Use the correct tool for your application. The correct tool will do the job better and safer at the rate for which it is designed.
- Use clamps or another practical way to secure and support the workpiece to a stable platform. Holding a tool by hand or against the body is unstable and may lead to loss of control.
- Keep the tool and its handle dry, clean and free from oil and grease. Always use a clean cloth when cleaning. Never use brake fluids, gasoline, petroleum-based products, or any strong solvents to clean your tool.
- Do not use the tool as a hammer.
- Never use this tool in a manner that could cause a fastener to be directed toward anything other than the workpiece.

- Never use gasoline or other flammable liquids to clean the tool. Never use the tool in the presence of flammable liquids or gases. Vapors could ignite by a spark and cause an explosion which will result in death or serious personal injury.
- Always fit the tool with a fitting or hose coupling on or near the tool in a way that all the remaining compressed air in the tool is discharged at the time the fitting or hose coupling is disconnected. Do not use a check valve or any other fitting which allows air to remain in the tool. Death or serious personal injury could occur.
- Never carry the tool by the air hose or pull the hose to move the tool or a compressor. Keep hoses away from heat, oil and sharp edges. Replace any hose that is weak, worn, or otherwise damaged. Personal injury or tool damage could occur.
- Always assume the tool contains fasteners. Respect the tool as a working implement; no horseplay.
- Do not drop or throw the tool. Dropping or throwing the tool can result in damage that will make the tool unusable or unsafe. If the tool has been dropped or thrown, examine the tool closely for an air leak or bent, cracked or broken parts. STOP and repair before using, or serious injury could occur.
- Avoid using the tool when the magazine is empty. Accelerated wear on the tool may occur.
- Clean and check all air supply hoses and fittings before connecting the tool to an air supply. Replace any damaged or worn hoses or fittings. Tool performance or durability may be reduced.
- Do not use the tool if it leaks air or does not function properly.
- Do not operate the tool if it does not contain a legible warning label.
- Always carry the tool by the handle. Never carry the tool by the air hose.

TOOL SERVICE

- Only use accessories that are identified by the manufacturer for the specific tool model.
- Use of unauthorized parts or failure to follow maintenance instructions may create a risk of injury.
- Only use the lubricants supplied with the tool or specified by the manufacturer. Tool service must be performed only by qualified repair personnel.

OPERATION

- Do not drive fasteners near the edge of workpiece. The workpiece may split causing the fastener or ricochet, potentially injuring you or people around.
- Do not drive fasteners on top of other fasteners or with the tool at an overly steep angle. This may cause deflection of fasteners which could cause injury.
- Do not actuate the tool unless you intend to drive a fastener into the workpiece.
- Always handle the tool with care:
 - ◆ Respect the tool as a working implement.
 - ◆ Never engage in horseplay.
 - ◆ Keep others a safe distance from the tool while tool is in operation as accidental actuation may occur, possibly causing injury.

AIR SUPPLY AND CONNECTIONS

- The connector on the tool must not hold pressure when air supply is disconnected. If an incorrect fitting is used, the tool can remain charged with air after disconnecting and thus will be able to drive a fastener even after the air line is disconnected, possibly causing injury.
- Do not use any type of reactive gases, including, but not limited to, oxygen and combustible gases, as a power source. Use filtered, lubricated, and regulated compressed air only. Use of a reactive gas instead of compressed air may cause the tool to explode which will cause death or serious personal injury.
- Only use a pressure-regulated compressed air source to limit the air pressure supplied to the tool. The regulated pressure must not exceed 115 psi. If the regulator fails, the pressure delivered to the tool must not exceed 200 psi. The tool could explode which will cause death or serious personal injury.
- Always disconnect the air source:
 - ◆ Before unloading or making adjustments.
 - ◆ When maintaining the tool.
 - ◆ When clearing a jam.
 - ◆ When touching the safety yoke.
 - ◆ When tool is not in use.
 - ◆ When moving to a different work area.

Such precautionary measures reduce the risk of injury to persons.

LOADING TOOL

- Do not load the tool with fasteners when any one of the operating controls is activated.
- Never place a hand or any part of body in fastener discharge area of tool.
- Never point the tool at anyone.

WARNING:

The warnings and precautions discussed above cannot cover all possible conditions and situations that may occur. It must be understood by the user that common sense and caution are factors which cannot be built into this product, but must be supplied by the user.

UNPACKING

- This tool has been shipped completely assembled.
- Carefully remove the tool and any accessories from the box.
- Inspect the tool carefully to make sure no breakage or damage occurred during shipping.
- Do not discard the packing material until you have carefully inspected and satisfactorily operated the tool.
- If any parts are damaged or missing, please call 1-888-669-5672.

WARNING:

If any parts are missing do not operate this tool until the missing parts are replaced. Failure to do so could result in possible serious personal injury.

WARNING:

Do not attempt to modify this tool or create accessories not recommended for use with this tool. Any such alteration or modification is misuse and could result in hazardous condition leading to possible serious personal injury.

FEATURES

SPECIFICATIONS

- AIR CONSUMPTION:** 5.3 SCFM with 100 fasteners per minute @ 90 psi
- AIR INLET:** 1/4 inch NPT
- MAGAZINE CAPACITY:** 120 pcs
- WEIGHT:** 8.5 lbs
- MAXIMUM PRESSURE:** 115 psi
- PRESSURE RANGE:** 70 psi – 115 psi
- FASTENER SIZE RANGE:**

6/25" (6 mm)	
32 mm	1-1/4"
38 mm	1-1/2"
45 mm	1-3/4"
(18 Gauge)	

Compatible with generic 18 gauge L cleats.

FEATURES

ERGONOMICALLY DESIGNED HANDLE
For ease of operation and reduced fatigue.

NON-MARRING DESIGN
Provides increased protection from marring when working with a finished flooring surface.

DURABLE CONSTRUCTION
Lightweight, high-strength aluminum body with heat treated steel parts.

FIBERGLASS Mallet WITH RUBBER HEAD INCLUDED

OPERATION

PREPARE THE TOOL

The tool is shipped with the Arm (A) part detached from the main body part. Follow these instructions to prepare the tool for use.

1. Set the Arm(A) against the Handle .
2. Wrench-tighten the Nuts(B) until the Arm(A) and Handle (C) are secured and the Arm(A) is locked against Handle(C).

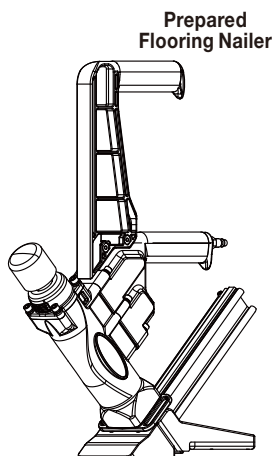
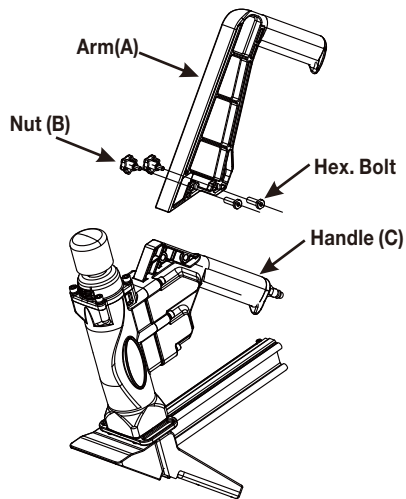

⚠ WARNING:

If any parts are missing, do not operate this tool until the missing parts are replaced. Before using this tool, make sure the arm part and the main body part are screwed together tightly. Failure to do so could result in possible serious personal injury.

LOADING L CLEATS

1. Connect the tool to the air source.
2. Insert strip of fasteners from the rear of magazine(D). Be sure the fasteners are pointed downward. (See figure 1 & figure 2)
3. This tool uses a spring loaded bypass lever in order to load and upload the nails. Once the nails are properly inserted, pull the pusher(E) completely back, pressing against the bypass lever (F) of the pusher. (See figure 3)
4. Once the pusher hits the back of magazine, allow the pusher to slide forward and engage the nails, pushing them to the nose of the tool. (See figure 4)

Figure 1

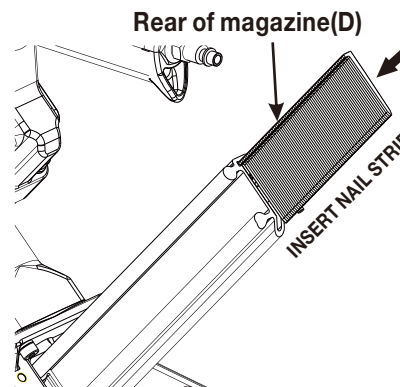

Figure 2

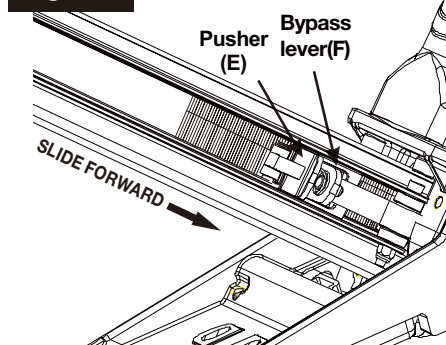

Figure 3

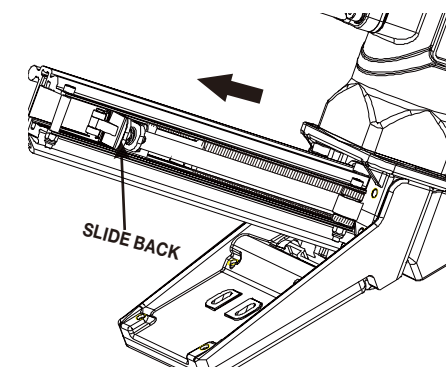
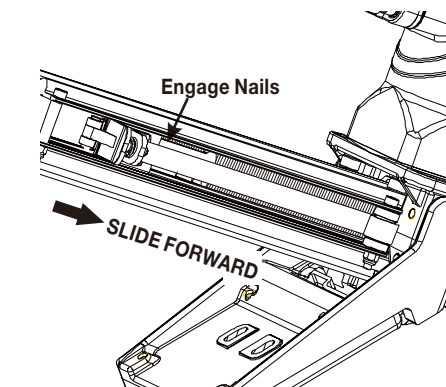

Figure 4



⚠ WARNING:
The tool may fire when it is first connected to the air source. Always connect the tool to the air source before loading fasteners to prevent injury from unintended cycling. Always make sure the tool's magazine is empty at the beginning of each work session, before connecting to an air source.

⚠ WARNING:
Only use those fasteners recommended for use with this tool. Fasteners not identified for use with this tool by the tool manufacturer are able to result in a risk of injury to persons or tool damage when used in this tool.

UNLOADING L CLEATS

1. Disconnect the tool from the air source.
2. Pull back the pusher, pressing bypass lever of the pusher allow to pusher to bypass nails and slowly allow pusher to return to nose of the tool.
3. Slide the fastener to the rear magazine.

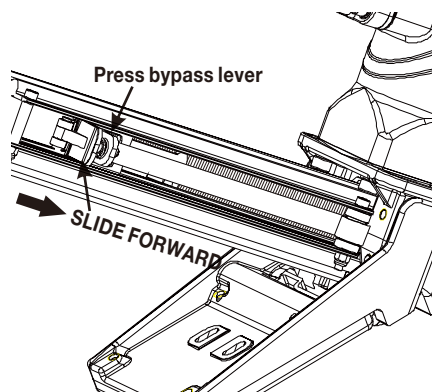

CHANGING THE FOOT PLATE

The tool is equipped with a factory pre-installed 9/16 in. to 5/8 in. foot plate (G). and an additional uninstalled 3/4 in. and 3/8 in. to 1/2 in. foot plate and 7/16 in. flooring shim.

To change the plate:

1. Disconnect the tool from the air source.
2. Empty the magazine completely.
3. Fire the tool into a piece of scrap wood to ensure there is no compressed air or fasteners left in the tool.
4. Set the tool on its side to expose the four screws (H).
5. Remove the four screws (H), then remove the foot plate.
6. Align the four screw holes in the replacement foot plate with the four threaded mounting holes.
7. Using the four screws you removed just now, secure the replacement foot plate to the tool.
8. Ensure the correct Foot Plate is installed by firing into a scrap piece of flooring and checking for proper fastener placement.

⚠ WARNING:
Disconnect the tool from the air source whenever changing the foot plate. Make sure there is no fastener in the magazine before changing the foot plate.

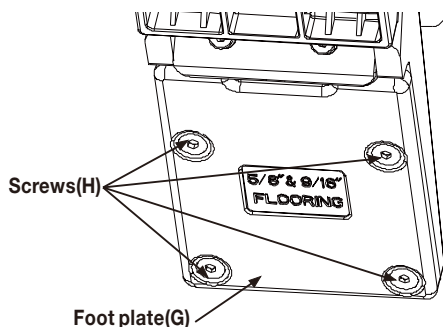

ADJUSTING THE FRONT FOOT

The tool is equipped with an adjustable front foot, can be adjusted for 3/8 in. to 3/4 in. wood floors. This tool is shipped out set for 5/8 inch & 9/16 inch wood floor.

To adjust the front foot (I):

1. Disconnect the tool from the air source.
2. Empty the magazine completely.
3. Fire the tool into a piece of scrap wood to ensure there is no compressed air or fasteners left in the tool.
4. Set the tool on its side to expose the two Bolts(J) and two Small Plates (K).
5. Loosen these two Bolts (J) to move the Front Foot (I) in the range of the Adjust Groove (L).
6. Adjust the proper position of the Front Foot (I) according to the actual thickness of wood floors and then lock tightly these two Bolts (J).
7. Ensure the correct front foot set for the wood floor by firing into a scrap piece of flooring and checking for proper fastener placement.

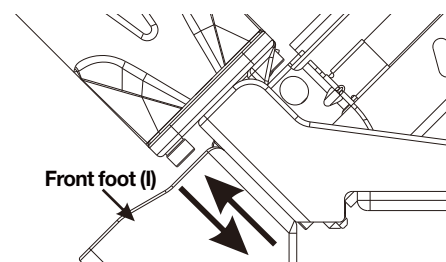
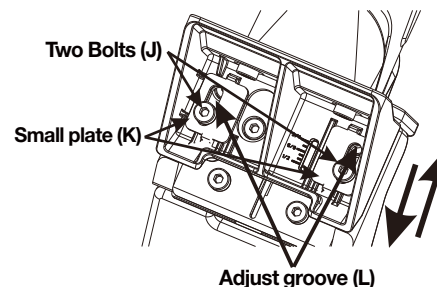

⚠ WARNING:
Disconnect the tool from the air source whenever changing the foot plate. Make sure there is no fastener in the magazine before changing the foot plate.

SETTING THE AIR PRESSURE

1. The amount of air pressure required depends on the size of the fasteners and the workpiece material.
2. Begin testing the depth of drive by driving a test nail into the same type of workpiece material used for the actual job.
3. Drive a test fastener with the air pressure set at 90-95 psi.
4. Raise or lower the air pressure to find the lowest setting that will perform the job with consistent results.

OPERATING THE TOOL

1. Attach the tool to the air source. Start your compressor and check the pressure, making sure it is set between 70-115 psi. Do not exceed the maximum 115 psi.
2. Hold the hand grip (N) securely and press the foot plate (G) to the work surface. Make sure the plate is over the fastener target position.
3. Press down firmly so that the foot plate (G) is firmly contacting the work surface. Then, using the mallet packed with the tool, strike the hammer cap (M) firmly to drive the fastener into work surface. Lift the tool off the work surface. Repeat this process until the job is completed.

Tongue and groove flooring

The flooring nailer is designed for tongue and groove flooring only. Place the nailer flush onto the work surface and ensure that you are striking at the tongue of the hardwood floor.

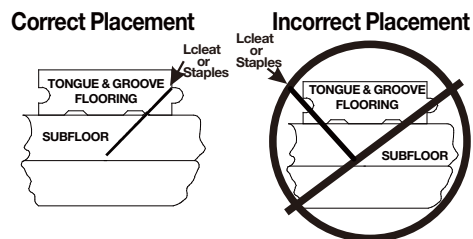
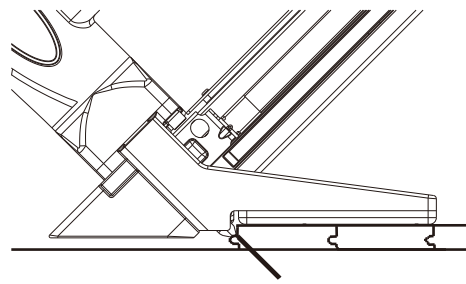

NOTE: Please follow your wood manufacture's guidelines when doing your flooring installations.

4. When finished, make sure to store the tool in a clean, dry, safe location out of reach of children and other unauthorized people.

WARNING:
Extreme caution must be used whenever this tool is connected to an air source. If the tool is dropped, or if the hammer cap (M) is accidentally struck, then the tool will fire a fastener, potentially causing **SERIOUS PERSONAL INJURY.**

WARNING:
Keep your feet off the tool.

WARNING:
Before using the tool on a floor, test the tool on a scrap piece of wood. Adjust the driving depth by providing more or less air pressure. Never exceed 115 PSI.

WARNING:
An improperly functioning tool must not be used. Do not actuate the tool unless the tool is placed firmly against the work piece.

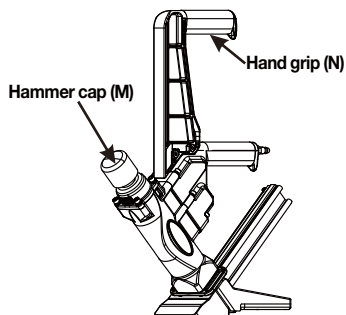

CLEARING JAMS

Occasionally, fasteners may become jammed in the firing mechanism of the tool, making the tool inoperable. To remove a jammed fastener, follow these steps below:

1. Disconnect the tool from air source.
2. Empty the magazine. Make sure all fasteners are removed.
3. Try to fire the tool into a piece of scrap wood or flooring to make sure that it's incapable of firing any fasteners.
4. Set the tool on its side to expose the Nose Bolts(O).
5. Remove three Nose Bolts (O), slide the Drive Guide(P) out to expose the jammed fastener. (See figure 5)
6. Remove jammed fastener, using pliers or a screwdriver if required. (See figure 6)
7. Return the Drive Blade back to its original position. (See figure 7)
8. Replace the Nose Guide (P) and Nose Bolts(O). (See figure 8)
9. Reconnect tool to the air source, then reload the tool with fasteners.
10. Press the tool against a piece of wood, and test fire the fasteners several times to check for proper operation. If the tool is properly firing, you may continue using the tool. If the tool fails to perform properly, immediately discontinue use and have the tool repaired by a qualified service technician.

Figure 5

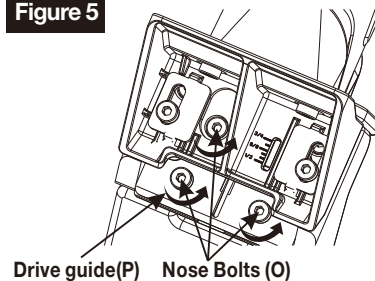

Figure 6

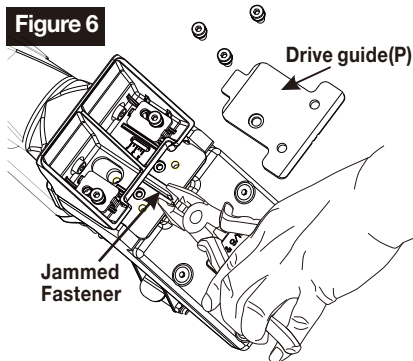

Figure 7

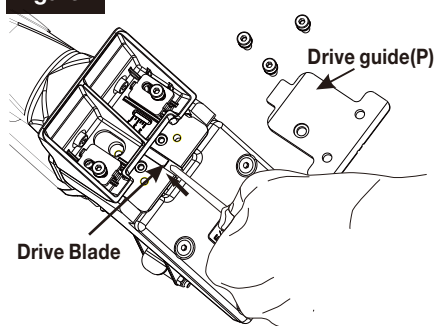
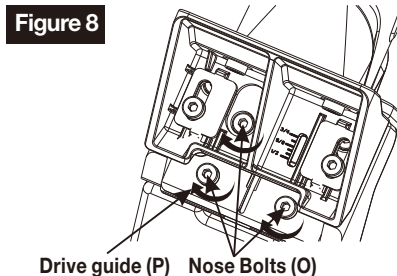

Figure 8



WARNING:
Make sure there is no fastener in the magazine before clearing a jam.

MAINTENANCE

WARNING:
Any time inspection, maintenance, and cleaning are done: Disconnect the tool from the air source. Empty the magazine completely.

ANTI-DUST

Each tool is packed with an anti-dust cap on the air connector, check it after unpacking. Keep the anti-dust cap cover the air connector when the tool is not in use.

LUBRICATION

Frequent, but not excessive, lubrication is required for best performance. Oil for the tool added through the air line connection will lubricate the internal parts.

1. Disconnect the tool from the air source to add the lubricant.

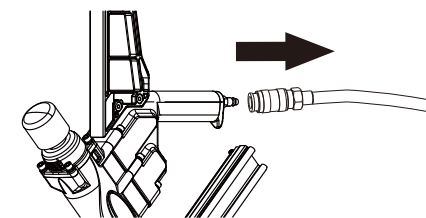

2. Turn the tool so the air inlet is facing up. Place 2-3 drops of pneumatic fastening tool oil into air inlet. Do not use detergent oil or additives as these lubricants will cause accelerated wear to the seals and bumpers in the tool, resulting in poor tool performance and frequent tool maintenance.

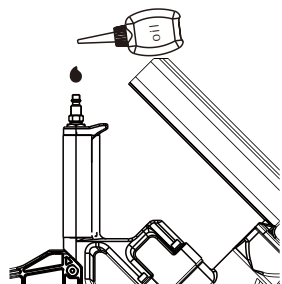

3. After adding oil, run tool briefly. Wipe off any excess oil from the cap exhaust.

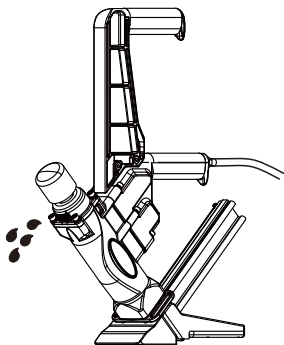

CAUTION:
Lubricate tool only with specified lubricants.

CLEANING

Avoid using solvents when cleaning plastic parts. Most plastics are susceptible to damage from various types of commercial solvents and maybe damaged by their use. Use clean cloths to remove dirt, dust, oil, grease, etc.

WARNING:
Do not at any time let brake fluids, gasoline, petroleum-based products, penetration oils, ect. come in contact with plastic parts. Chemicals can damage, weaken, or destroy plastic which may result in serious personal injury.

COLD WEATHER OPERATION

For cold weather operation, near and below freezing, the moisture in the air line may freeze and prevent tool operation. We recommend the use of air tool lubricant or permanent antifreeze (ethylene glycol) as a cold weather lubricant.

CAUTION:
Do not store tools in a cold weather environment to prevent frost or ice formation on the tool's operating valves and mechanisms that could cause tool failure.

RECOMMENDED HOOKUP

1. The air compressor must be able to maintain a minimum of 70 psi when the tool is being used. An inadequate air supply can cause a loss of power and inconsistent driving.
2. An oiler can be used to provide oil circulation through the tool. A filter can be used to remove liquid and solid impurities which can rust or gum up internal parts of the tool.
3. Always use air supply hoses with a minimum working pressure rating equal to or greater than the pressure from the power source if a regulator fails, or 150 psi, whichever is greater. Use 3/8 in. air hose for runs up to 50 ft. and use a 3/8 in. quick coupler on the air hose.
4. Use a pressure regulator on the compressor, with an operating pressure of 0-125 psi. A pressure regulator is required to control the operating pressure of the tool between 70 and 115 psi.

CAUTION:
The air compressor must be able to maintain a minimum of 70 psi when the tool is being used. An inadequate air supply can cause a loss of power and inconsistent driving.

WARNING:
Do not connect with an air compressor which can potentially exceed 200 psi. As tool may burst, possibly causing injury.

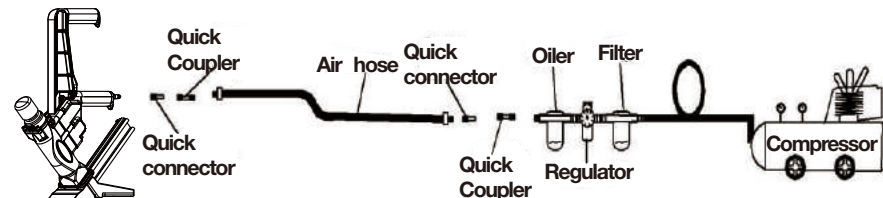

TROUBLESHOOTING

WARNING:

Stop using tool immediately if any of the following problems occur. Serious personal injury could result. Any repairs or replacements must be done by a qualified service person or an authorized service center.

PROBLEMS	POSSIBLE CAUSES	CORRECTION ACTIONS
Driving blade does not retract.	1. Zero or Low air pressure.	1. Check air supply for 70 psi minimum to 115 psi maximum.
	2. Lack of lubrication.	2. Manually lubricate through male air inlet fitting.
	3. Excessive dirt inside nailer.	3. Disassemble and clean.
	4. Bent or burred driving blade.	4. Replace driving blade.
	5. Seals worn out.	5. Replace all seals.
Driving blade retracts slowly.	1. Low air pressure.	1. Turn up air pressure to 70-115 psi max.
	2. Bent or burred driving blade.	2. Replace driving blade.
	3. Air supply restricted by small orifice.	3. Use 1/4" minimum diameter air fittings.
	4. Piston O-ring worn out.	4. Replace O-ring.
	5. Excessive dirt inside nailer.	5. Disassemble, clean and lubricate.
Nail is not countersunk.	1. Low air pressure.	1. Turn up air pressure to 70-115 psi max.
	2. Broken Driving Blade.	2. Replace Driving Blade.
	3. Nail hit hard surface.	3. Move from obstruction.
	4. Piston O-ring worn out.	4. Replace O-ring.
	5. Worn out nose.	5. Replace nose.
Nailer leaks air.	1. Air supply fittings loose.	1. Tighten all air line fitting connections.
	2. Excess air pressure blew out seals.	2. Check air supply for 115 psi Maximum replace all seals.
	3. Cracked or damaged body.	3. Replace body.
	4. Seals worn out.	4. Replace all seals.
	5. Seals need to be seated.	5. Dry fire Nailer.
Bottom of nailer cracked off.	1. Operated without rubber bumper installed.	1. Replace damaged parts.
	2. Excessive air pressure used.	2. Replace damaged parts.
Nails jam in nailer.	1. Wrong size of fasteners.	1. Use 18 gauge L cleats.
	2. Continued use after a short hit.	2. Clear nail immediately after short hit.
	3. Nail pusher damaged or spring broken.	3. Replace nail pusher assembly.
	4. Nail channel lose.	4. Tighten nail channel retaining screws.
	5. Bent nail stuck in nail guide.	5. Disassemble and clear out bent nail.
	6. Hit another set nail or hard object.	6. Move from obstruction.
	7. Nose worn out.	7. Replace nose.
Plunger locked up-won't move or fire	1. Lack of lubrication	1. Manually lubricate through male air inlet fitting.

WARNING:

Use only Numax authorized repair parts. For questions please call 1-888-669-5672 or visit our website at <http://www.numaxtools.com>

WEARABLE PARTS

Repair parts can be ordered from our website: <http://www.numaxtools.com>

PGP INC. PRODUCT WARRANTIES

NUMAX Pneumatic Nail Guns Warranties

1 Year Professional Tool Warranty

The Numax Tool limited warranty extends exclusively to the original purchaser of the Numax Product, begins on the date of purchase and excludes wearable parts. During the warranty period Prime Global Products, Inc. (PGP) expressly warrants that the Numax Product is free from defect in materials and workmanship subject to the exceptions and limitations contained herein. PGP shall at its option, repair, replace, or offer a full refund for a Numax Product that has a defect in materials or workmanship.

30 Day Wearable Parts Warranty

The Numax wearable parts limited warranty extends exclusively to the original purchaser of the Numax Product and begins on the date of purchase, and includes driver blades, bumpers, O-rings, pistons, piston rings, and gaskets. During the warranty period PGP expressly warrants that the Numax Product is free from defect in materials and workmanship subject to the exceptions and limitations contained herein. PGP shall at its option, repair, replace, or offer a full refund for a Numax Product that has a defect in materials or workmanship.

A DATED SALES RECEIPT OR PROOF OF PURCHASE FROM THE ORIGINAL RETAIL PURCHASER IS REQUIRED TO MAKE A WARRANTY CLAIM. Warranty registration is also required and can be accomplished through On-Line Product Registration at www.numaxtools.com, select SUPPORT, select PRODUCT REGISTRATION. To make a warranty claim, the original purchaser must return the Numax Nail Gun, postage prepaid and insured, with proof of purchase to PGP or any of its authorized service centers. For questions please call 1-888-669-5672. Other than the postage and insurance requirement, no charge will be made for repairs covered by this warranty.

Warranty Exclusions

These Warranties do not apply where:

- Repairs or alterations have been made, or attempted, by others, and/or the unauthorized use of non-conforming parts or accessories.
- Repairs are required due to normal wear and tear.
- The Nail Gun has been abused, misused, improperly maintained or operated, including: the failure to use clean, dry, regulated compressed air at the recommended pressure; accidents caused by use of the Numax Product after partial failure.
- The Numax Product is used commercially in assembly lines or production lines. The Numax Product is intended for use by individuals and these warranties do not extend to such commercial uses.

NO WARRANTY, ORAL OR WRITTEN, EXPRESSED OR IMPLIED, OTHER THAN THE ABOVE WARRANTIES IS MADE WITH REGARD TO THIS NUMAX PRODUCT. ANY IMPLIED WARRANTIES WILL BE LIMITED IN DURATION TO THE APPLICABLE WARRANTY PERIOD SPECIFIED ABOVE. SOME STATES DO NOT ALLOW LIMITATIONS ON HOW LONG AN IMPLIED WARRANTY LASTS, SO THE ABOVE MAY NOT APPLY TO YOU. YOUR REMEDIES ARE SOLELY AND EXCLUSIVELY AS STATED ABOVE. PGP SHALL IN NO EVENT BE LIABLE FOR INCIDENTAL, CONSEQUENTIAL, INDIRECT, OR SPECIAL DAMAGES. SOME STATES DO NOT ALLOW THE EXCLUSION OR LIMITATION OF INCIDENTAL OR CONSEQUENTIAL DAMAGES, SO THE ABOVE LIMITATION OR EXCLUSION MAY NOT APPLY TO YOU. IN NO EVENT, WHETHER AS A RESULT OF A BREACH OF CONTRACT, WARRANTY, TORT (INCLUDING NEGLIGENCE) OR OTHERWISE, SHALL PGP'S LIABILITY EXCEED THE PRICE OF THE PRODUCT WHICH HAS GIVEN RISE TO THE CLAIM OR LIABILITY. ANY LIABILITY CONNECTED WITH THE USE OF THIS PRODUCT SHALL TERMINATE UPON THE EXPIRATION OF THE WARRANTY PERIOD SPECIFIED ABOVE. NO EMPLOYEE OR REPRESENTATION OF PGP, OR ANY DISTRIBUTOR OR DEALER IS AUTHORIZED TO MAKE ANY CHANGE OR MODIFICATION OF THIS WARRANTY.

These warranties give you specific legal rights. you may also have other rights which vary from state to state.

THESE WARRANTIES ARE SUBJECT TO CHANGE WITHOUT NOTICE.